



STANEQ

PRO

TENNIS BALL MACHINE

USER MANUAL

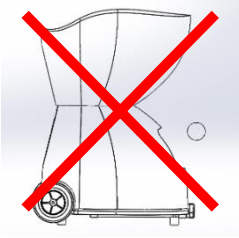

TABLE OF CONTENTS

Security Warnings	3-5
Parts of the machine	6-7
Before First Use	8
Unboxing	8
Caution	9
Storage	9
Maintenance	9
Transportation	10
Battery And Charging	10
Battery Replacement	10
Charger	11
Charge The Battery	11
External Battery	11
AC Adapter	12
Calibration	12
Usage	13-15
Control Panel Interface Introduction	15
Remote Control	16
Training and Throwing Details	17-19
Tennis Balls	19
Customer Care	20
Support	20
Warranty	20
Warranty Method	20
Warranty Conditions	21
EC Declaration Of Conformity	22

SECURITY WARNINGS

This tennis ball machine is designed and tested to ensure safe play, provided that it is used in accordance with the following safety warnings. Failure to follow below instructions may result in serious personal injury or property damage.



- Stay away from the front of the machine
- where the ball is out.
- Keep clear of the ejection point. Do not stand in front or near the mouth of the machine. Balls may eject unexpectedly.
- Keep children away from the machine
- while the machine is running.
- Keep people with physical and mental disabilities away from the machine while the machine is running
- Adult supervision is recommended at all times.
- Do not put your hand or foreign objects in front of the machine.
- If the ball gets stuck and the ball gets inside, cut off the electricity of the machine and take the ball after the rotating parts stop.
- Never touch the spinning wheels.
- Do not put your hand in the rotating part in the ball hopper, do not try to place the balls , do not interfere.
- It can be dangerous and harmful if things (clothes, hair, fingers, etc.) enter the rotating part of the ball hopper.



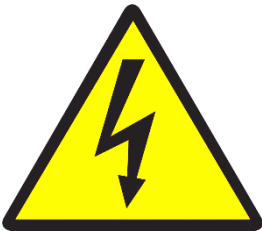

- Do not put new ball while the machine is running and the rotating part in the ball hopper.
- The machine should not be used in wet conditions and rain.
- Keep away from water.
- Keep the machine in dry environment.
- The charger is only to be used indoors.
- Do not spray water, do not wash with water.
- Never operate the machine while the machine is charging.
- In an emergency, the lower right button on the back cuts off the power completely. (Turn it to the “0” position.)
- Wait for a while after turning off the power, the wheels may continue to spin.
- The charger is a 24V 1A battery charger. Do not plug in any other device or adapter.
- Do not apply 110v or 220v directly to the charging socket of the machine, it is dangerous.
- Do not touch the charger if it is wet, remove it after closing the general fuse (plug fuse). Also, do not reuse the wet battery and charger.
- If your machine has an internal or external battery:
- Keep sparks and flames away from the battery (i.e. no smoking)
- Do not use the battery if it has swollen or expanded.



- Only use a 24V battery with this machine (or alternative approved by your distributor).
- When replacing the battery, the terminals should be wrapped with electrical tape or a heat shrinkable sleeve.
- Use correct removal methods.
- The machine is 19 kg. Lift the machine carefully.
- The packaging box is 27 kg. (raise two people)
- Keep your machine clean. Contaminants such as dust and leaves inside your machine can pose a burning hazard. Please regularly vacuum your machine from your mouth.
- Do not use the machine in explosive atmospheres, it may generate sparks. May pose a risk of explosion.
- A multi-purpose/dry chemical extinguisher should be used to extinguish any flame.
- Use tennis ball in your machine. Do not use cricket balls it will damage your machine.
- This machine should not be used to throw any object other than a tennis ball.
- The recommended ball is a training (non-pressure) ball. Our machine is suitable for both orange (stage 2) and green (stage 3) low pressure balls. Red (Stage 1) balls of large sizes cannot work.

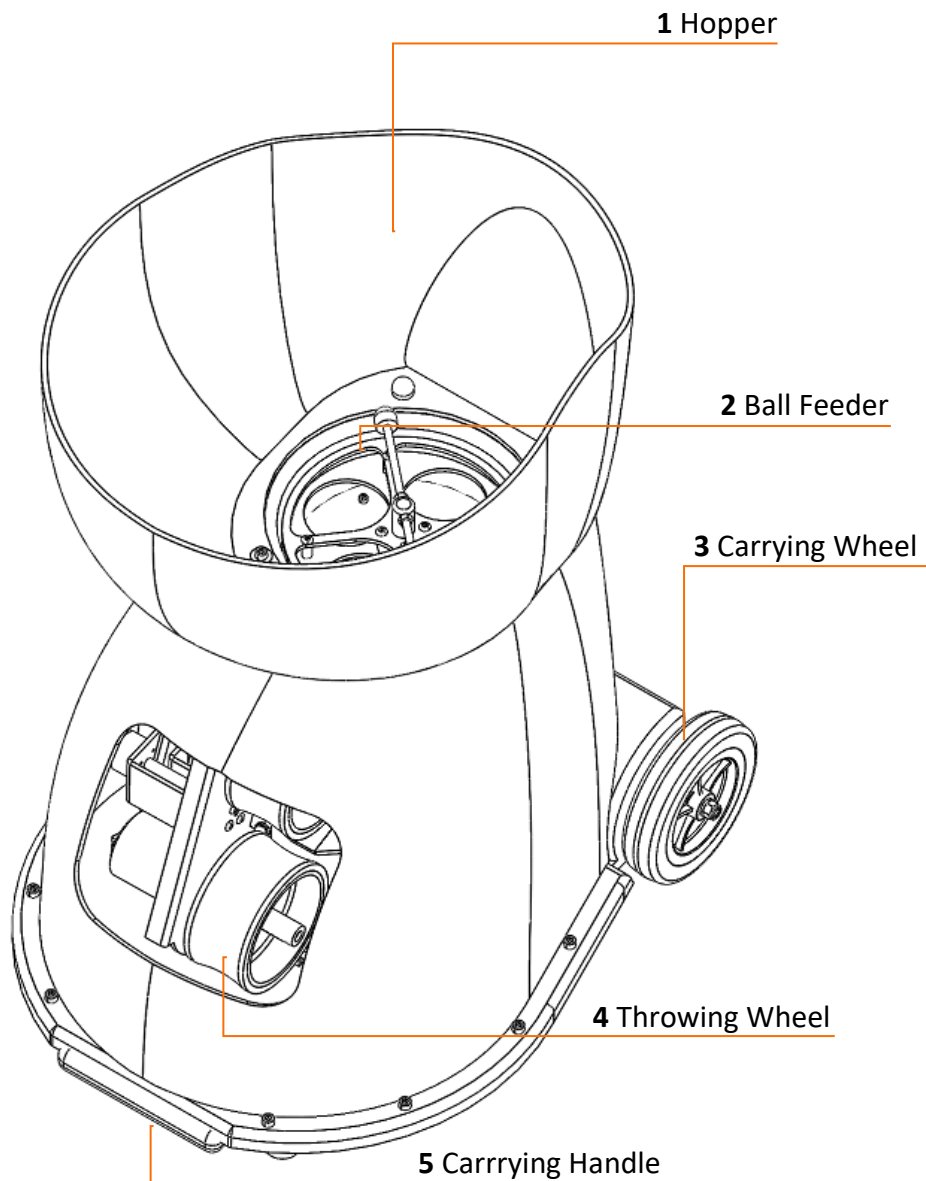

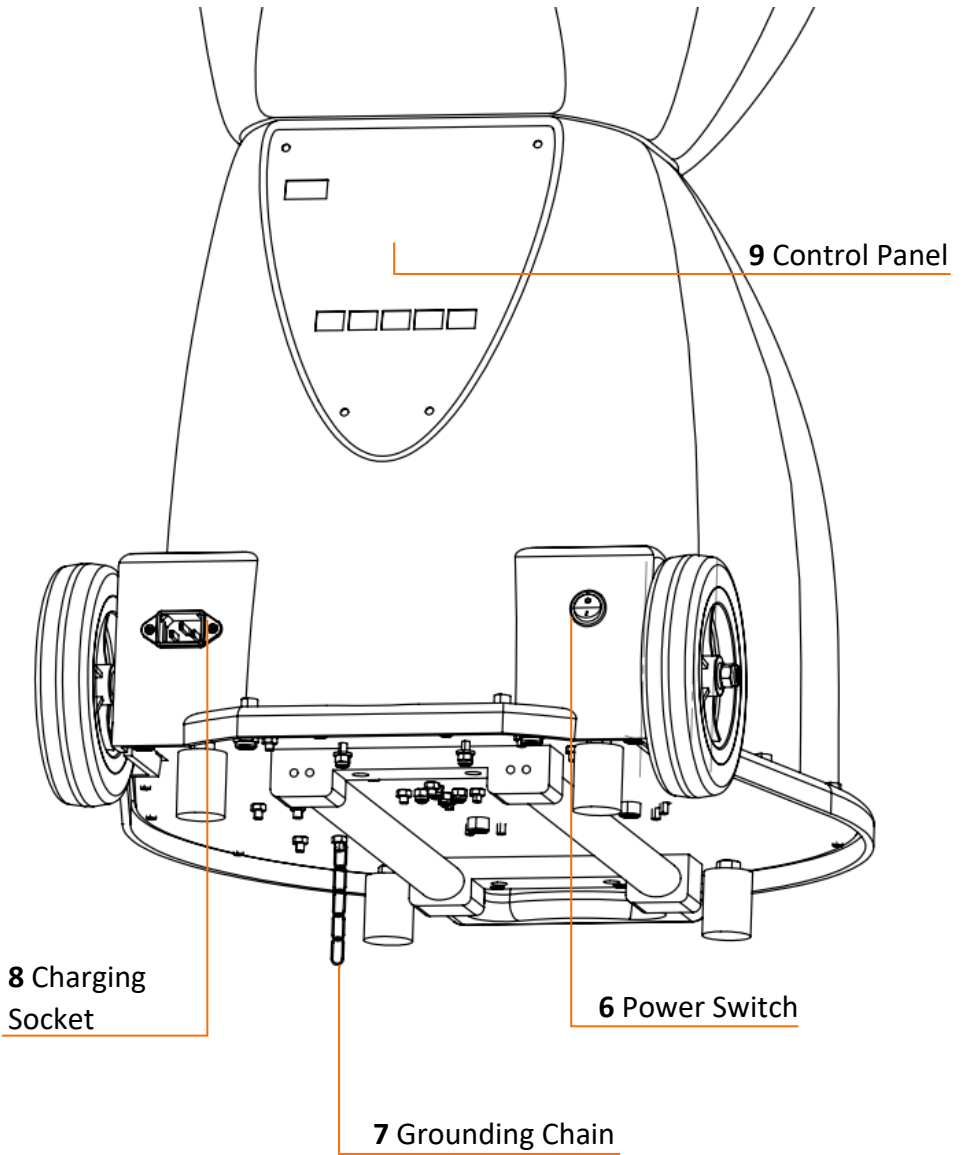

BEFORE FIRST USE

When you first open your box, you may notice some cosmetic scratches on your machine, especially the ball hopper on the top of the machine. This is completely normal and part of the manufacturing process.

You may also notice a yellow ball feather inside your machine or on the launch wheels. This is also normal as every machine is tested with balls as part of our quality control process (the wheels are then wiped, but all traces of ball fluff are difficult to remove).

UNBOXING

Please read the entire user manual.

When transporting, carry it in an upright position.

First take out the charger from the box.

Get help from a person while taking the machine out of the box and take it out by holding the bottom plate.

Check the machine for damage that may occur during transportation.

Items out of the box:

- Machine
- Hopper of machine
- Charger
- Remote Controller
- User Manual

After removing all parts, turn the ball hopper upside down and place it on the machine. You can start the machine by turning the power button on the bottom right of the machine to the "1" position. You may need to return your machine to its supplier in the future, so we recommend keeping the box.

You can install the hopper upright for operating mode and upside down for transport/storage. To install the bin, align it correctly and then press down until it locks into place.

CAUTION

This machine is designed for use on the tennis court and is not to be used under any other circumstances. Only tennis balls should be used, no other balls should be thrown from the machine. Red level tennis balls should also not be used. Never stand in front of the machine unless you are on the other side of the tennis net (more than 7 meters away). Never stand in front of the machine, even if it is stopped, as the balls can fly at any time. Children should always be supervised and taught to never stand in front of the machine. Do not use the machine in the rain and avoid using a wet ball. It is recommended to use non-pressure balls to give your machine the best performance. Using a combination of new and old balls will produce inconsistent results.

STORAGE

We recommend storing your machine in a closed area, preferably with the cover closed for protection. Do not expose your machine to rain, even with the cover guard, as rain can damage your machine. Do not expose your machine to direct sunlight and keep it on its rubber feet. Do not position it sideways or upside down. Keep your machine away from explosive atmospheres, do not store it in high temperature environments.

MAINTENANCE

At the end of 3-4 workouts, with the machine turned off, clean the dust and fluff inside with the help of the vacuum machine from the mouth part. The outside of the machine can be wiped with a soft damp cloth, but please be careful not to get water inside the machine. During maintenance, the grounding chain, machine components and connecting parts (bolts, nuts, etc.) must be checked and robust. Also, with heavy use, the ejector wheels and batteries may need to be replaced. If you play on clay or a very porous surface, we recommend wiping the inside of your launch wheels once a month (clay build-up can cause your wheels to become unstable).

TRANSPORTATION

To move the machine, slide out the handle on the front of the machine (bottom). Lift the machine by the arm until it rests on the rear wheels. You just need to pull the machine to your target. Never move the machine while it is on. Please ensure that the machine is always upright. Putting it on its side may cause damage and void your warranty. Do not store the machine in your car when the temperature exceeds 30 degrees.



BATTERY AND CHARGER

Attention! Never press the power button while the machine is charging! The charger is not for starting the machine. It works with the battery inside the machine!

The charge of your machine should take between 3-8 hours depending on the settings you use. Follow the battery information from the indicator at the top left of the phone program. Do not use and charge when the indicator drops below 10%. Even if you do not use the machine, you must charge it once a month, otherwise the battery may deteriorate.

BATTERY REPLACEMENT

Only replace with a 25.6 Volt LiFePO (8 series 3.2V) battery. Please use electrical tape or something similar to cover the battery terminals. Do not keep the battery near a source of flame or smoke. Avoid short-circuiting the battery to avoid fire. **Please do not reverse the terminals! There is no reverse polarization protection. The circuit board of your machine will be damaged and will be out of warranty.**

CHARGER

The charger is the most suitable charger for the machine. It is normal for it to become slightly warm during charging. You should use your charger for charging in a dry environment. This charger is suitable for 8S LiFePO battery. You should use it to charge the batteries in the machine. Please note that this charger cannot be used to power the machine directly.

CHARGING THE BATTERY

Connect the charger to the machine or external battery first. The green light will turn on. Plug the other triangle-like end of the charger into the socket on the lower left side of the back of your machine. The RED (charge) light will turn on.

When the battery is full, the GREEN light (full) will turn on.

Please unplug first from the socket and then the charger from the machine when the green light turns on. The filling process is expected to take 3-8 hours.



EXTERNAL BATTERY

If you bought the machine with an external battery option or later bought an external battery, please read this section. When using your battery, please **keep it away from rain, water or**



wet ground. It is essential that the battery case or socket never get wet. Use the external battery in a dry and closed place. Avoid prolonged exposure to the sun. STANEG and its distributors are not responsible for the problems that may arise in these and similar situations. To use with external battery, place the male end on the machine and start the machine in position 2(II). To charge, place the male end of the charger on the female end of your external battery. **Do not charge your external battery while it is plugged into the machine.**

AC ADAPTER

If you want to use the machine with an AC adapter, obtain it from STANEG or its distributors. When using the AC adapter, **please keep it away from rain, water or wet ground.** Never get the AC adapter or socket wet. Use the adapter in a dry and closed place. Avoid prolonged exposure to the sun. STANEG and its distributors are not responsible for the problems that may arise in these and similar situations. To use with AC adapter, first plug the adapter into the socket, then insert the socket part into the machine and start the machine in position 2(II).

CALIBRATION

If you want to position the machine in a new location, you need to calibrate. If you are doing the calibration for the first time, we recommend that you read the USAGE section on the next page. Calibration is done when SPEED 6 and HORZ (horizontal) is 15 in the training program called MANUEL. After placing the machine on the middle line, the ball is thrown by pressing the play button and the machine is calibrated by turning it right or left until it drops to the middle line. Note: You can determine the height of the ball with the ELEV(elevation) option according to the state of your balls.

USAGE



The machine can be placed just behind the so-called center mark on the court, but placed elsewhere to create different workouts. (note that features such as oscillation may also not work correctly when the

machine is not positioned in the centre). Please add the balls to the hopper before starting, do not add the balls while the agitator is rotating, otherwise it may cause ball jamming. The maximum capacity is 150 balls. Please do not overfill the hopper as excess weight may damage the feed motor.



Press the power button of your machine. If you are using the internal battery, set it to position 1(I), if you are using an external battery or AC adapter, set it to position 2(II) and start the machine. **To charge, set the switch to position 2.**

Choose one of 9 programs.

Select speed, spin, ball frequency and vertical axis settings.

If you have chosen one of the vertical oscillation, lobe or manual programs, select the horizontal axis setting.

To start, press the start button on the top right.

- Speed: Allows the ball to be thrown faster or slower.
- Spin: It allows the ball to be thrown with +1 and +2 topspin, -1 and -2 backspin.
- Frequency: Sets the ball to be thrown with a frequency of 2-10 seconds.

- Vertical: Changes the vertical angle. By increasing it, it can be ensured that the ball comes from higher. It has a variable between 1-30 and is about 30 degrees. 15 is the middle part.
- Horizontal: Changes the horizontal angle. This setting is active in Depty (vertical swing), Lobe and Manual programs. It has a variable between 1-30 and is about 30 degrees. 15 is the middle part.

CONTROL PANEL INTERFACE INTRODUCTION

The indicator at the top left is the percent expression of the battery fullness indicator of your machine. It can measure with an error of +10 -10, this is normal.

In addition, when the ball toss starts, the expression “PLA”, that is, play takes place.

The start button on the top right is for starting and stopping the workout.

9 green button represent 9 different training modes.

10 different orange gray buttons determine the speed, spin-slice, frequency, vertical and horizontal characteristics of the ball that comes out in the training.

If your machine has started to throw balls, it will not allow program changes.

REMOTE CONTROLLER

You can perform all the functions on the control panel with your remote control. If your machine is in play mode, every time you press a key, the machine will beep. If your machine is in the pause state, there will be no beeps, you can see the changes on the control panel.

Your remote uses 433,4 Mhz radio frequency. It works at a distance that can comfortably detect the length of a tennis court. If your remote control is not working properly, please replace the battery. (14250 3.6V Li-SOCI) Please do not reverse polarity when changing batteries. A

remote control can affect more than one machine at the same time. If you have more than one machine, you need to program it separately, in this case, please contact us.



TRAINING AND THROWING DETAILS



Sweep: It performs his throw on the court in the form of a horizontal swing. When a row ends, it continues from where it threw the first ball. Thus, at the end of 5 balls, it allows you to dribble to the other side. If you want him to shoot faster during training, it will be enough to touch the top button in the Speed tab. If it shoots outside of the court due to your speed increase, please press the lower button on the Vertical (vertical) buttons to make the ball come lower, so your ball will fall into the court.

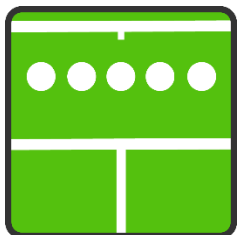

Random: It is a mixed version of the horizontal swing training program. It allows you to train attention and reflexes by throwing the ball to a different place than the next. The Speed and Vertical setting are valid as for horizontal swing.



Drill: It is a program that oscillates both horizontally and vertically. After the first ball comes, the second ball comes forward on the vertical axis. The third ball moves in the vertical and horizontal axis. When 10 balls are finished, it returns to the beginning from the position where the first ball came from. During the training, if your balls coincide with the net, press the upper button from the Vertical adjustment buttons. If your balls are coming out of the court, press the lower button from the vertical adjustment buttons.



programs.

2-Line Narrow: This program allows you to alternate forehand and backhand strokes by throwing the ball to the right and left of the midline. But it keeps you in a narrow range. It allows you to train without running. Speed and vertical settings are the same as in previous



2-Line Medium: This program allows you to alternate forehand and backhand strokes by throwing the ball to the right and left of the midline. It keeps you in a range that will take a few steps. Speed and vertical settings are the same as in previous programs.



2-Line Wide: This program allows you to alternate forehand and backhand strokes by throwing the ball to the right and left of the midline. But it keeps you in a wide range. You have to make your strokes by running. Speed and vertical settings are the same as in previous programs.



Depth: It shoots on the court in the form of a vertical swing. Throws the ball between the baseline and the service line. You have to hit the ball by running forward and backward. During the training, if your balls coincide with the net, press the upper button from the Vertical adjustment buttons. If your balls are coming out of the court, press the lower button from the vertical adjustment buttons. You can make vertical oscillations in different parts of the court from the horizontal adjustment keys.



Lob: Allows you to perform Slam Dunk training in the lob program. You can shoot to different areas with the horizontal adjustment button. Setting the Vertical close to 30 will make the ball come from the air. The speed setting allows it to come from higher and fall backwards.



Manuel: You can throw your balls wherever you want on the court by using the Horizontal and Vertical adjustment keys. You can produce different shots by placing your machine in different places. You can record all of these programs.

TENNIS BALLS

Use a tennis ball in your machine. Do not use cricket balls, it will damage your machine. This machine should not be used to throw any object other than a tennis ball. Your machine can hold 150 balls. While the hopper can probably hold a larger amount than that, we recommend limiting it to 150 balls, which weighs less on the rotary engine. We strongly recommend using non-pressure balls, preferably from a reputable brand. Pressure cannons can also be used, but their pressure will drop over time, resulting in inconsistent shots. The machine is suitable for both orange (2nd stage) and green (3rd stage) low pressure balls. It cannot work with large red (1st stage) balls.

CUSTOMER CARE SUPPORT

When calling support, please provide us with the serial number located on the base of your machine. Also, any video footage that will show the problem will greatly assist us in solving your problem. If you hear any unusual sounds, please report them and where the sound is coming from.

WARRANTY

If any part fails during the warranty period due to defective workmanship or faulty materials, Staneg or its distributor will repair or (at distributor option) repair the defective part free of charge. The warranty period is country specific, please contact the Staneg distributor in your country or your dealer for details.

WARRANTY METHOD

The warranty is managed by your country's authorized Staneg distributor. For the contact information of your country's Staneg distributor, please visit our website: www.staneg.com . Be sure to let us know all the details about your machine, including the serial number and model, and a detailed description of the fault, to ensure your warranty service request is processed quickly. Exposure of the ball machine to foreign matter should be minimized. Please close the cover of the machine after the game is over. Damages that cause your machine to be exposed to foreign substances are not covered by the warranty.

This warranty covers the purchaser or any other person for damage, malfunction or loss due to:

- The lack of maintenance, abuse, neglect, misuse, accident or misuse of this device.
- Makinede çizikler, oyuklar, aşınma veya genel aşınma ve yıpranma.
- Scratches, dents, wear or general wear and tear on the machine. Garanti süresi boyunca izinsiz onarımlar.

- Natural disasters.
- Use at power voltages other than those specified for your machine.

In these cases, the service is paid.

Under no circumstances shall Staneg or its authorized distributors be liable to the customer or any other person for any damages, including but not limited to personal injury or damage to property, and for any resulting damage.

WARRANTY CONDITIONS

- The machine will be delivered to the Staneg distributor service department or authorized service representative and shipping charges will be paid by the owner either way. No liability is accepted for loss or damage in transit.
- The machine should always be operated and maintained in accordance with the instructions given.
- No modifications or repairs may be made without prior approval from the Distributors. Such repairs or replacements do not extend the warranty period.
- Proof of purchase must be provided to verify the date of purchase and establish the warranty period. Only the original purchaser applies under this warranty.
- The warranty period is calculated only from the date of purchase.
- In cases where this warranty does not comply with the law of the region in which it is located, the legal rights of the purchaser will be governed.
- Parts loaded from other manufacturers' products will void this warranty.



EC Declaration of Conformity

We, 'STANEG MACHINERY MANUFACTURING INDUSTRY IMPORT EXPORT' LIMITED COMPANY declare under our sole responsibility that the machine below

**ADDRESS: İvedikköy Mah. 1487 Cad. Emporium BC: No: 28
Yenimahalle /ANKARA- TÜRKİYE**

Machine Name:	Tennis Ball Machine
Machine Type:	Staneg Pro Model
Year of Construction:	2021
Serial No:	3

is in conformity with the directives and the standards mentioned below:

- 2006/42/EC Machinery Directive,

Regulations Applied according to Harmonize Standards:

- EN ISO 12100-1:2010 Safety of Machinery - Basic Concepts, General Principles for Design, Part 1: Basic Terms- methodology
- EN 60204-1:2018 Safety of Machinery- Electrical equipment of machines Part 1: General requirements

Name, Surname: **Yunus Emre Tuğlu**

Position: **General Manager**

Signature:

Place: **Ankara / Turkey**

Date of Issue: **20.11.2021**